

Modeling heat flow across fuel-fired crucible furnace using ADINA

¹Atanda, P. O., ¹Olorunniwo, O. E., ¹Abioye, A. A. and ²Oluwole, O. O.

¹Department of Materials Science and Engineering, Obafemi Awolowo University, Nigeria.

²Department of Mechanical Engineering, University of Ibadan, Nigeria.

Abstract -The study simulated the heat flow across a fuel-fired crucible furnace using ADINA Software. Appropriate engineering materials were selected for the design and construction of the fuel fired crucible furnace. Among several parameters taken into consideration were strength/weight ratio, formability, cost and ability to fulfill specific service functions. Heat dissipation to the outside was minimal and this was clearly shown in the temperature gradient. Heat dissipation was uniform within the flame gap and inside the crucible pot. The Kaolin refractory material used showed very good insulation capacity significantly reduced heat losses. The modeled temperature distribution profile, heat flux and the temperature gradient were all in agreement with the validated results.

Index terms: modeling, fuel-fired crucible furnace, heat flow, temperature



Corresponding author: Oluwole.O.O; email:oluwoleo2@asme.org

1 INTRODUCTION

A furnace is an apparatus in which heat is generated and transferred directly or indirectly to a molten or solid mass for the purpose of effecting a physical, chemical or metallurgical change in the mass [1],[2],[3],[4]. Furnace is equipment isolated from the surrounding by an insulated wall and is used to transfer heat to the material to be melted or heat treated within the furnace [5]. An ideal furnace is one in which all energy produced is utilized, this practically unachievable and there is no thermal processing equipment with efficiency of 100% [6]. A furnace of high efficiency is therefore a system in which energy losses are minimal According to [7]. Furnace can be classified according to the firing techniques; direct-fired and indirect-fired furnace. In direct-fired furnace the product of combustion has direct contact with the surface of the workload, this workloads are affected by the product of combustion. Indirect-fired furnaces are for heating materials and products for which the quality of the finished products may be inferior if they have come in contact with flame or products of combustion. In such cases, the stock or charge may be (a) heated in

an enclosing muffle (conducting container) that is heated from the outside by products of combustion from burners or (b) heated by radiant tubes that enclose the flame and products of combustion ([8].

A pot furnace or crucible furnace is a form of muffle furnace in which the container prevents product of combustion contact with the load. [4]. Ideally, all heat added to the furnaces should be used to heat the charge, load or stock. In practice, however, a lot of heat is lost in several ways. The losses include energy conversion losses, furnace wall losses, furnace opening losses and the likes [1],[2],[3],[4]. In order to prevent these losses, materials that can retain and conserve heat known as refractory materials are therefore used as lining materials for the furnaces. Refractories are porous, multi-component and heterogeneous materials composed of thermally stable mineral aggregate, a binder phase and additives. Since furnace will be operating at a very high temperature, the refractory materials are needed to withstand temperatures over and above these temperatures. Refractories are inorganic, non metallic and heat resistant materials that can withstand the action of abrasive or corrosive solids, liquids or gases at high temperatures [9]. The refractory material

must be able to withstand high temperature, withstand sudden changes of temperatures, withstand load and abrasive forces, conserve heat, and must be able to withstand action of molten metal, hot gasses and slag erosion. The principal raw materials used in production of basic refractories are magnesites, dolomite, chrome ore, spinel and carbon [10], [11]. For this work, ADINA (which is commercial finite element software) was used for the simulation of the heat flow across the fuel-fired crucible furnace. ADINA has been widely used in industry and research institutes for linear and nonlinear finite element analysis of solids and structures, heat transfer, computational fluid dynamics and computational electromagnetics. It also provides a wide range of analysis capabilities for multiphysics problems including fluid-structure interactions and thermomechanical coupling [12].

A common example is in the Analysis of engine assembly and it has been an attractive analytical tool for problems in the car industry. In addition to the built-in model generation and meshing capabilities of the ADINA System, it also provides interfaces to many CAD/CAE software programs for easy importing of the model geometries and meshes. The results of the analyses can be visualized either with the ADINA User Interface or can be exported to other CAE software for post processing. It offers a comprehensive set of solution capabilities for solving linear and highly nonlinear, static/dynamic structural problems which may include large deformations/strains, severe material nonlinearities and contact conditions [13]. ADINA also offers a wide range of material models and reliable and efficient element technology, which is crucial in obtaining reliable solutions in complex analyses usually encountered in the automotive industry. The ADINA User Interface provides the complete pre- and post-processing capabilities for all the ADINA solution programs [13]. The ADINA User Interface offers a fully interactive graphical user interface for all the modeling and post-processing tasks.

2. Experimental Procedure

A 5.0 mm thick mild steel sheet of dimension 600 x 700 mm [11] was cut using cutting machine and rolled to shape using rolling machine to dimension

580 x 615 mm. These dimensions allow a tolerance of 3 mm x 5 mm. The rolled plate was joined at the edges by welding using electric arc machine to form a cylindrical shape which serves as the body of the cylinder. The tolerance was cut away to give the actual dimension of 577 mm x 610 mm (Figures 1 to 4). The base of the furnace was made from the mild steel sheet that was cut into a circular shape of diameter 580 mm; the circular plate was welded to the body of the furnace to give a solid base. A crucible cover of 577 mm x 150 mm was fabricated from the mild steel plate and a hole of 250 mm was fabricated on the cover to serve as an exhaust for the fumes and gases. Handles were attached to the crucible cover to allow for easy removal of the cover from the body of the furnace during loading of charges into the furnace and during removal of crucible pot from the furnace.

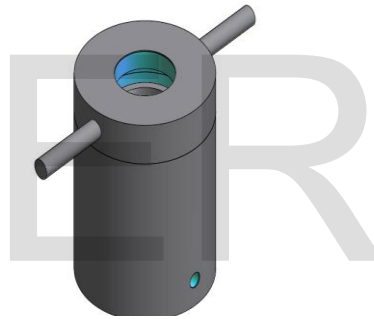

Figure1: Geometric View of crucible furnace

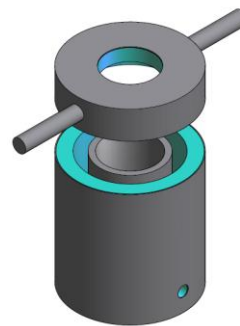

Figure 2: Exploded view of part of furnace

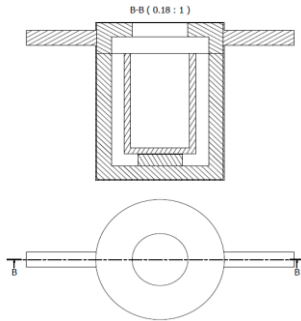

Figure 3: Cross-sectional view of furnace

Development and Lining of furnace for validation

The kaolin refractory materials were grinded and sieved using sieve of mesh 300 μm to have fine particles of the refractory, the kaolin materials were mixed and poured in to the furnace shell and rammed in the elastic mix while it is wet to produce a homogenous structure, this was done to give a bulk density in order to give volume stability and reduced the volume of open pores into which liquid can penetrate. The ramming and the filling of the kaolin into the furnace shell were done till the thickness of 70 mm was reached. The lining of the furnace was fired in order to give a dry, rigid and firm monolithic structure of refractory lining. The base of the crucible lining was molded in a platform pattern to give a seat for the crucible pot.

The crucible pot

The crucible pot is a standard part but due to the cost of procurement of the pot most of the small scale and medium scale industries may not be able to afford it. Therefore an alternative which was the use of compressor boiler plate and refrigerator condenser's cylinders, made of pressed alloy steel was selected. The crucible pot was made of boiler plant pressed alloy steel, the height of the crucible pot is 500 mm.

Simulation of the thermal flow across crucible furnace

ADINA Software was used for the modeling of the heat flow across the fuel fired crucible furnace. The methodology for the thermal flow across the

crucible furnace involves the following; definition of problem, modeling of the geometry of the crucible, definition of materials and material properties, definition of boundary condition, meshing, application of loads and running of current load steps

a. Definition of Problem

The first step in simulation is to define the problem, which is to simulate the heat flow across the fuel fired crucible furnace. The crucible furnace is made up of four units: The furnace wall, which is made up of mild steel sheet of 5mm thickness, the lining materials, the flame gap and the crucible pot. The thermal flow was simulated across these boundaries from outward to the inside wall of the crucible pot.

b. Modeling of the geometry of the crucible

The modeling of the fuel fired crucible was done in 2D so as to reduce the processor time of the system and to reduce complexity in modeling. The modeling of the geometry of the crucible furnace was done in three ways; definition of points of the crucible furnace, definition of lines and definition of surfaces. The coordinate's geometry of the crucible furnace was inputted in order to define the points of the crucible furnace on the software interface. The coordinates of the geometry is as shown in Table.1. The lines of the crucible furnace were defined by joining of the points together with respect to the geometry of the crucible furnace. The selections of the lines were done for the allocation of the surfaces with respect to the lines.

c. Definition of material in terms of material properties

Materials were assigned to each surface and the material properties were defined for each surface. The material properties such as thermal conductivities, heat transfer coefficient of convection and radiation for were assigned to individual materials. Table 2 shows the thermal conductivities of each material used in the construction of the crucible.

Table 1: Furnace Geometry coordinates

x1	x2	y1	y2
0	577	0	610
4	573	4	610
70	507	70	610
126	451	126	610
128	449	128	610
0	577	610	760
4	573	610	756
163	414	756	760
70	507	610	690
163	414	690	756

Table 2: Material Thermal Conductivities

Materials	Thermal Conductivity (W/mK)
Mild Steel	43
Kaolin (Mullite)	4
Dry air at 1350K	0.08253
Copper	401

Convective transfer(air) = 25 W/m²K

d. Definition of boundary conditions

The boundary conditions for the crucible furnace were defined; the environmental temperature of the foundry where the crucible furnace will be placed was measured 303 K and was inputted as boundary condition. The heat transfer coefficient of air convection (25 W/m²K) was also inputted as the boundary condition.

e. Meshing

Each material that was defined above was assigned to the geometry in step three above. The meshing density was defined to determine the mesh size. The mesh density was done in lines and also on the surfaces of the designed crucible. The mesh size was determined starting from coarse to fine mesh to achieve a convergence in result, then the free geometry meshing of the whole design was performed.

f. Application of loads

The temperature loads were assigned to the flame gap since it was the source of heat of the crucible furnace. The crucible pot was placed directly to

within the flame gap so has to have direct contact with the heat. The temperature load of 1473 K was applied to the flame gap surface with material of dry air with thermal conductivity of 0.8253 W/mK.

g. Running of current load steps

The current load steps were run to process the result. The post processing was carried out and the simulation of the thermal flow across the fuel fired crucible furnace was modeled. The plot of the result was given in nodal form.

Melting of the Copper in the Fuel Fired Crucible Furnace

In this stage the validation of the simulated thermal flow was done by melting copper in the fabricated crucible furnace. The results of modeling and the validation are presented in Figures 4 to 14. The results for the modeling processes are presented in Figures. 4 to 8. The modeling for the temperature distribution profile, heat flux, smoothed heat flux; error smoothed heat flux and the superimposed temperature distribution profile with the heat flux are presented in Figures 8 to 13. The graph showing the heat flow across the crucible furnace is presented in Figure 14.

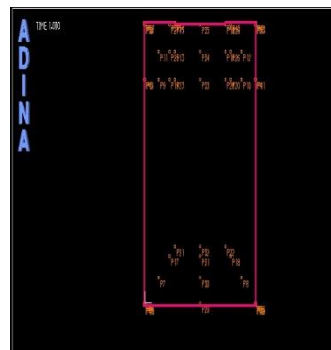

Figure 4: Point definition of Furnace

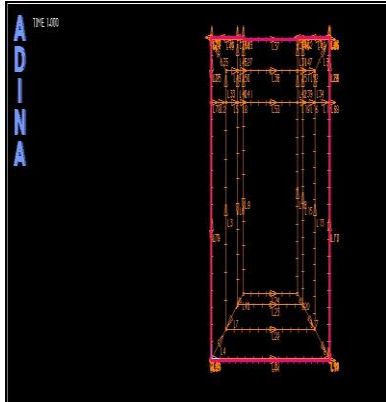

Figure 5: Line definition of Crucible

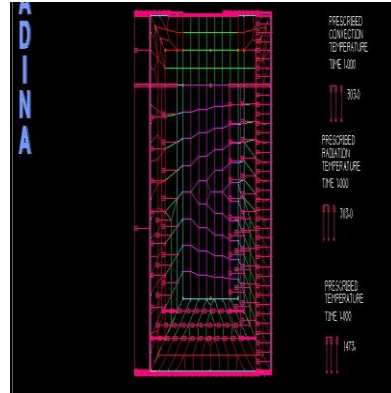

Figure 8: Application of loads to defined surfaces

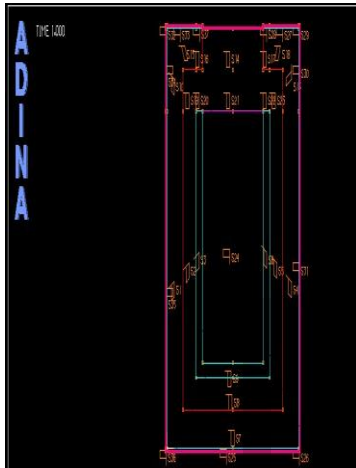

Figure 6: Surface definition of Furnace

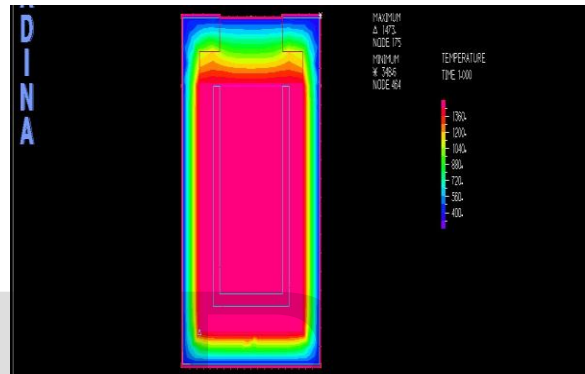

Figure 9: Temperature profile in furnace .
Temperature ranges from 1473K (inside) to 348.6K (furnace shell).

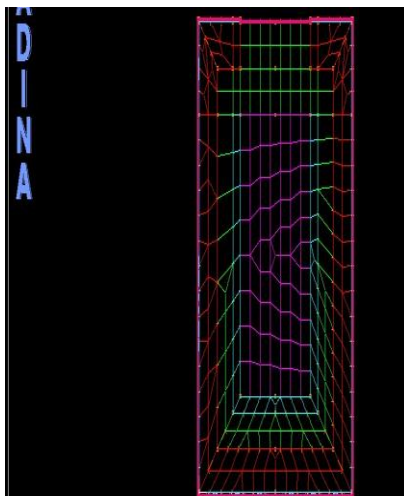

Figure 7: Meshing of Crucible Furnace

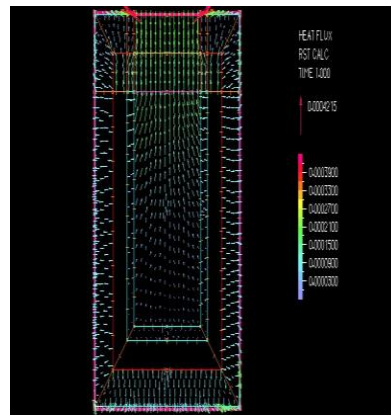

Figure 10: Heat flux in furnace

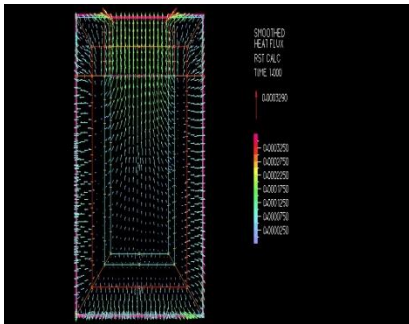

Figure 11: Smoothed Heat flux in furnace

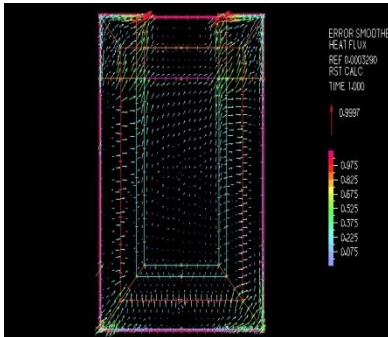

Figure 12: Error Smoothed Heat flux in furnace.

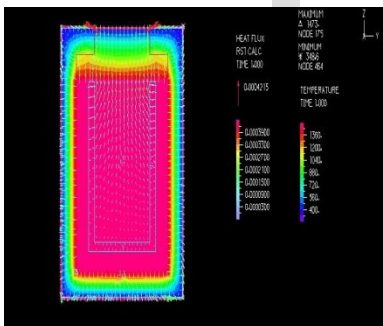

Figure 13: Superimposed heat flux with thermal distribution

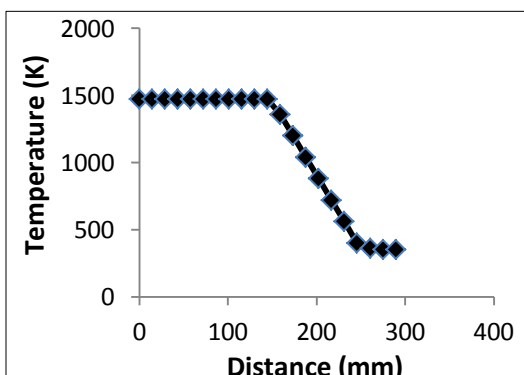

Figure 14: Temperature Gradient across Furnace

3. DISCUSSION OF MODELED AND VALIDATED RESULTS

The modeling gave the idea of the insulation thickness to be used and this was evaluated to be about 70 mm, thus with this thickness, the heat dissipation to the outside would be minimal and this is clearly noted in the temperature gradient model developed using ADINA software. The results showed that the refractory material used (kaolin) has a very good insulation capacity and made the heat losses to be significantly minimized. This is evident from the modeled temperature distribution profile, heat flux and the temperature gradient presented in Figures 9 to 14. The heat dissipation was uniform within the flame gap and inside the crucible pot though the source of heat was the flame gap, this was as a result of high thermal conductivity of the copper scraps charged inside the crucible pot (which was greater than that of crucible pot and the flame gap). The heat was reduced drastically across the kaolin linings to the furnace shell, due to its lower thermal conductivities. Also from the modeling of the crucible furnace showing temperature gradients during the heat transfer in the furnace, it could be clearly seen from Figure 14 that the kaolin refractory lining has high temperature gradient. This shows the effectiveness of kaolin as insulation in effectively reducing temperature across the crucible to the furnace shell to minimal level.

From the heat flux shown in the modeling of the furnace (Figures 10 to 12) and from the heat transfer from the copper inside the crucible pot through the refractory insulation to the shell (Figure 14), it could be seen that majority of the heat is retained in the crucible pot and the refractory insulation after reaching the desired temperature.

In order to validate the results of the theoretical models, furnace temperatures were measured both inside and outside with the aid of pyrometer and thermocouples, and the results of some routine checks and measurements were presented in Table 3. The performance level of the crucible furnace was as shown in Figure 15.

Table 3: Inside and Outside temperature measurement for modeled and validated fuel-fired crucible furnace

	Inside	Outside	Melts	% error inside	% error outside
Modelled Temp. (K)	1473	348.6			
Validated Temp. (K)	1455	353	1 st	1.26	-1.22
	1450	352	2 nd	1.26	-1.56
	1456	352	3 rd	0.98	-1.15
	1450	350	4 th	0.40	-1.56
	1452	354	5 th	1.54	-1.43

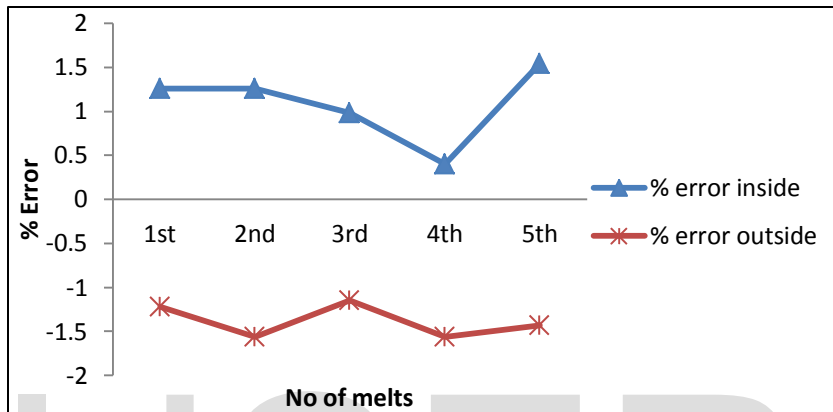

Figure 15: Graph of percentage error against number of melts

4. CONCLUSION

The result of this work showed that ADINA software proved to be a useful tool in simulating the heat flow in furnaces provided all the required parameters are selected carefully. The heat dissipation to the outside was minimal and this was clearly shown in the temperature gradient model developed using ADINA software. The Kaolin refractory material used has a very good insulation capacity and made the heat losses to be significantly minimized. This is evident from the modeled temperature distribution profile, heat flux and the temperature gradient. The heat dissipation was uniform within the flame gap and inside the crucible pot.

REFERENCES

[1]Gilchrist, J. D (1997), 'Fuels, Furnaces and Refractories', Pergamon Press.
 [2]Holman, J.P (1974), 'Heat Transfer' 3rd Ed. McGraw Hill Book Company, Toronto.
 [3]Schack, A (1965), 'Industrial Heat Transfer' 3rd Ed. McGraw Hill Book Company, New York.
 [4]Trinks W. (1967) 'Industrial Furnaces' Vol.1 and 2. John Wiley and Sons Inc; New York.

[5]Etherington, H and Ehtering, G (1961), 'Modern Furnace Technology' 3rd Ed. Charles Griffin and Company Ltd, London.

[6]Atanda, P. O. (2009) Development of Integrated salt bath isothermal heat treatment furnace unit for Austempering Ductile Iron. Ph.D. Thesis Project. Obafemi OAU Ile Ife Nigeria.

[7]Furnaces(2008)
 (<http://www.upton.thomasregister.com/olc/upton/page4.htm>). (Accessed 7 Mar. 2009)

[8]Degarmo E.P, Black J.T, and Ronald A. K. (1997), 'Materials and Processes in Manufacturing' 8th ed., Prentice Hall of India Private Ltd, New Delhi-110001.

[9]Chesti, A. R. (1986) 'Refractories manufacture, properties, and applications', Delhi, Prentice-Hall of India Private Limited.

[10]Davies, D.J and Oelmann, L.A (1983) 'The Structure, Properties and Heat treatment of Metal'; Pitman Book Ltd, London.

[11]Callister, W.D. (1978) Fundamentals of Materials Science and Engineering, 2nd ed. Wiley & Sons.

[12]"ADINA system, (2009) Encyclopedia Of Mathematics".
<http://eom.springer.de/A/a110390.htm>. Retrieved 2009-10-26.

[13]ADINA R&D Inc. (2009a)
<http://www.adina.com/index.shtml>. 29/09/2011